

**PolytheneOne.com**

**Instructions  
For sheeting a typical  
Single Span Polytunnel**

## Instructions For sheeting a typical Single Span Polytunnel

### Index of Contents

<u>Page No.</u>	<u>Description</u>
1.	Applying Protective Tape / Pads
2.	Trenching Around the Structure (when Trenching the Polythene in)
3.	Sheeting the Structure
4.	Aligning the Sheet
5.	Battening Around the Ends
6.	Initial Tensioning of Sheet (when using the Trenching in Method)
6a	Initial Tensioning of Sheet (when using the Timber Base Rail Method)
7.	Final Tensioning of Sheet
8.	Cladding Doors and Louvre Vents

# Applying Protective Tape / Pads

To get the maximum life from your polythene cover it is advisable to use Anti Hot Spot Tape which is a barrier tape designed to separate the polythene tunnel cover from the abrasion of the steel hoops and the excessive heat that builds up on the steel work of the polytunnel in the summer.

Anti Hot Spot Repair Tape should be used over existing old tape, as old Anti Hot Spot Tape degrades and gives off chemical vapour which is harmful to the polythene.

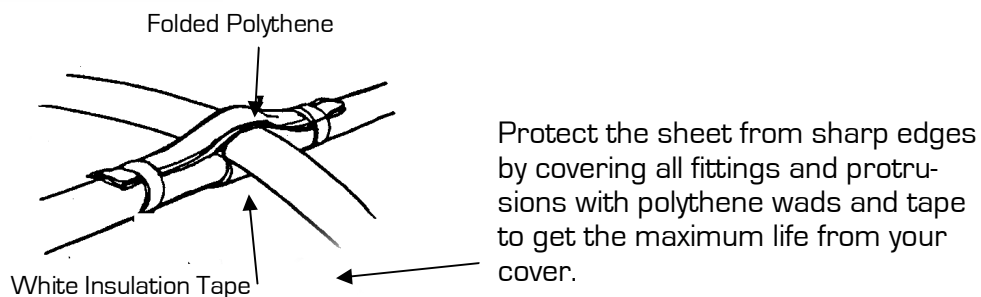
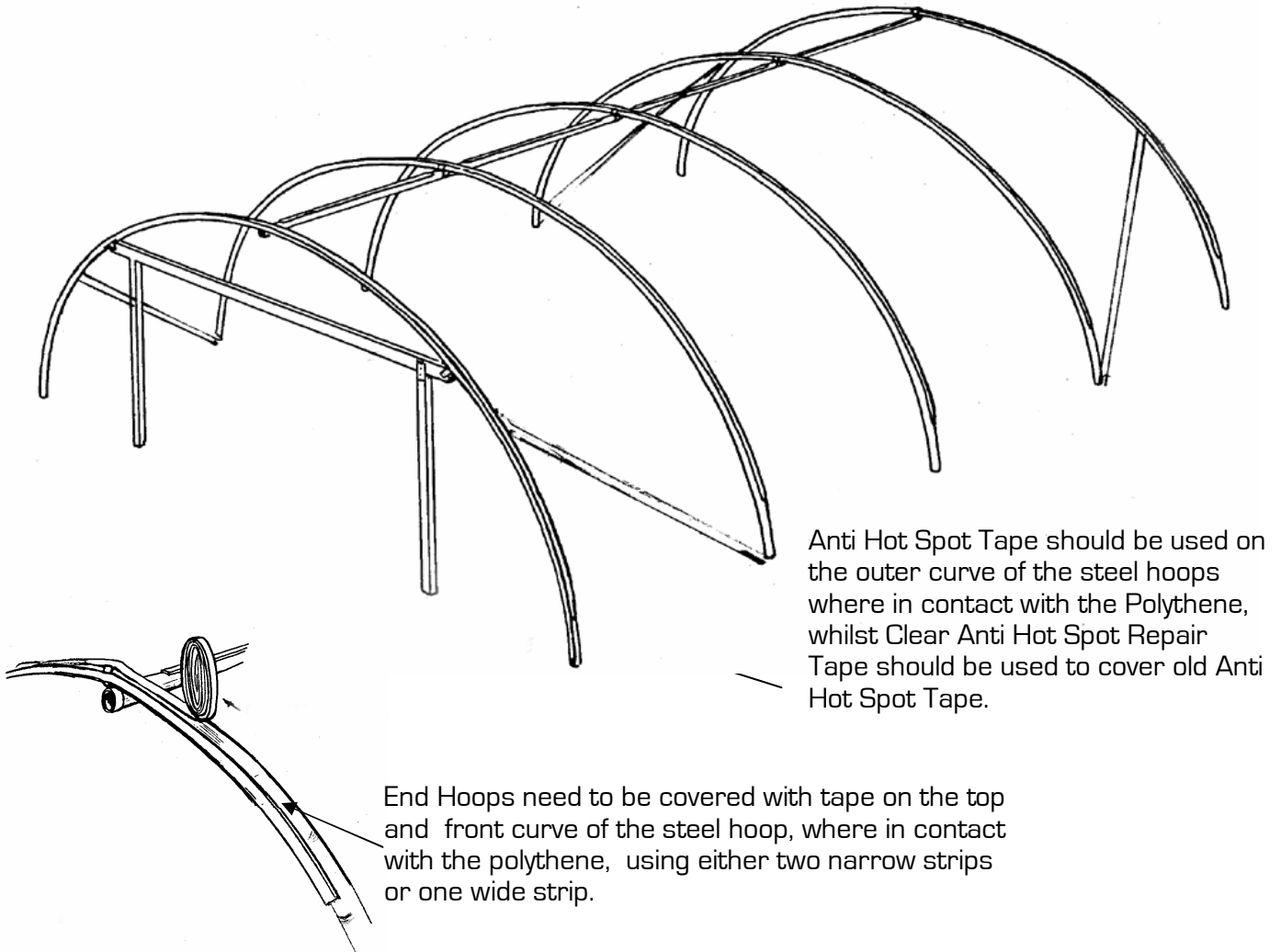

# Trenching Around the Structure

[When trenching the Polythene In]

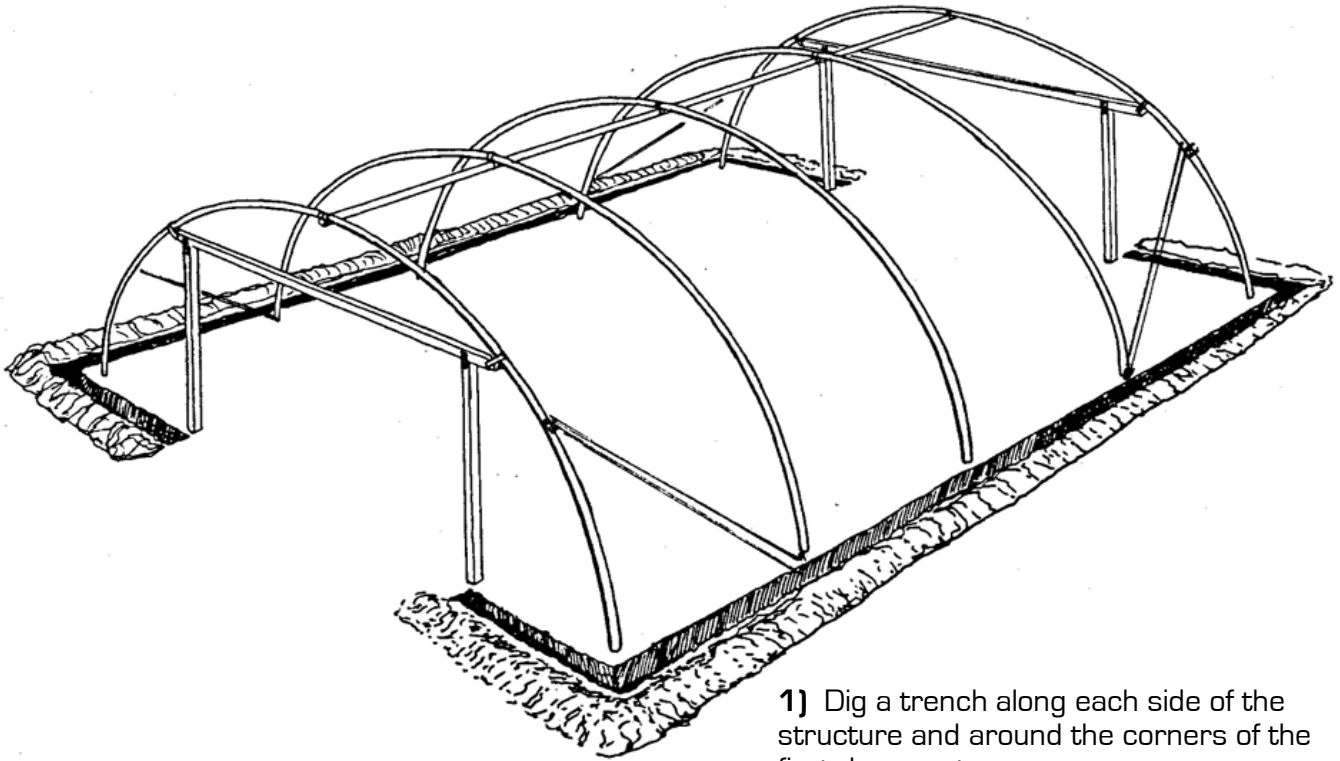

1) Dig a trench along each side of the structure and around the corners of the first door post

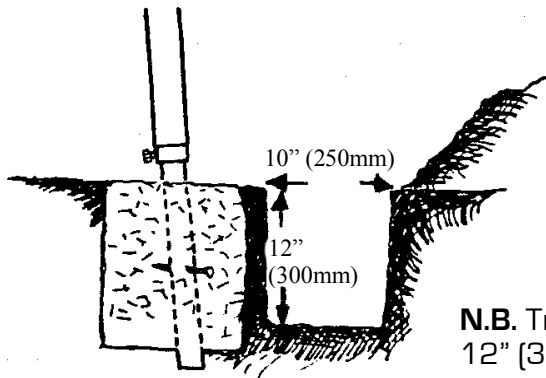

**N.B.** Trench must be 10" (250mm) wide by 12" (300mm) Deep

# Sheeting the Structure

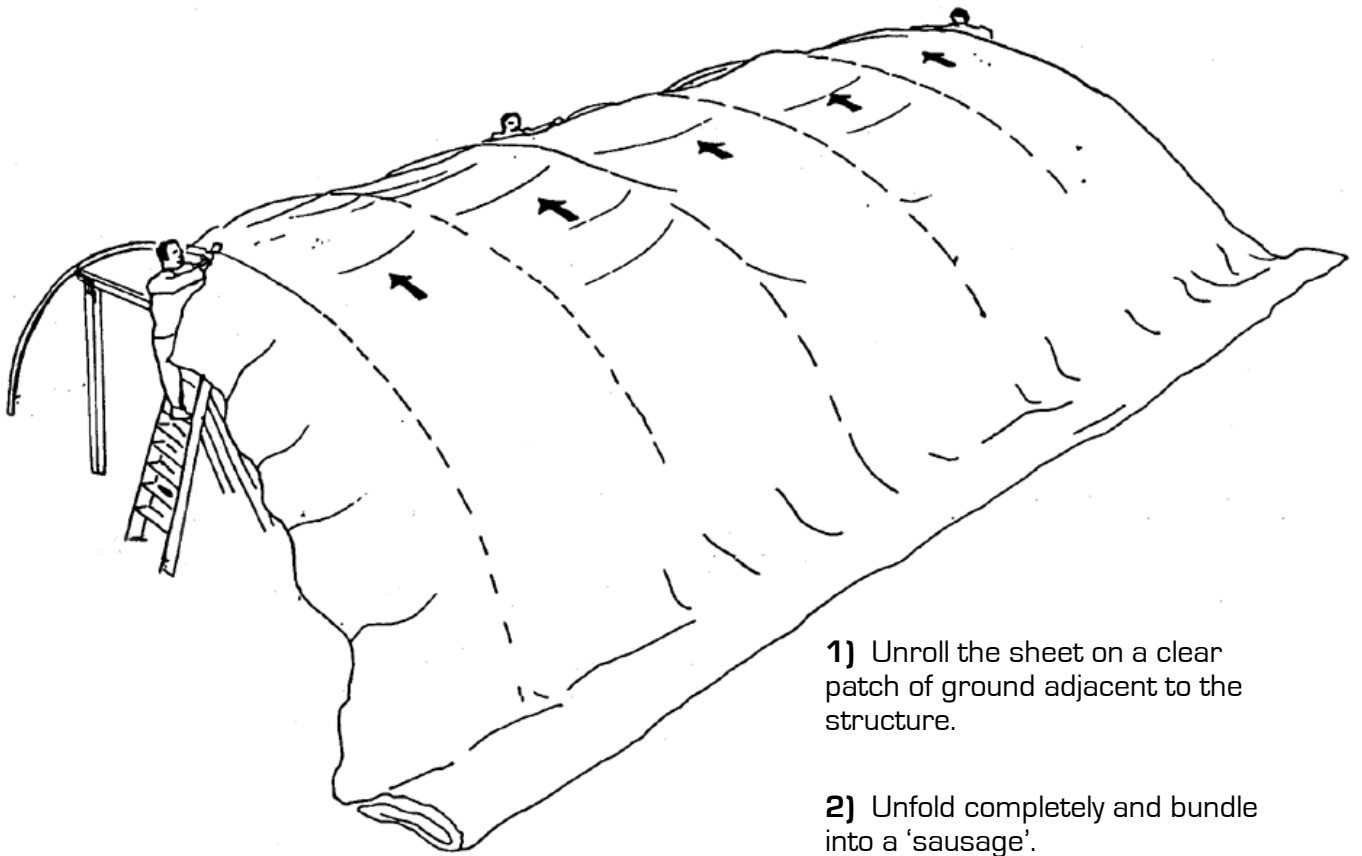

**1)** Unroll the sheet on a clear patch of ground adjacent to the structure.

**2)** Unfold completely and bundle into a 'sausage'.

**3)** With help lay the sheet along one side of the structure

**4)** Draw the sheet over the structure until it hangs to an equal amount each side.

## **NB:**

If the polythene supplied is Anti Fog and or Thermic Sterilite ensure that the cover is put on with the correct side facing inwards by ensuring that all writing on the film is readable from the inside. (i.e. not 'mirror writing')

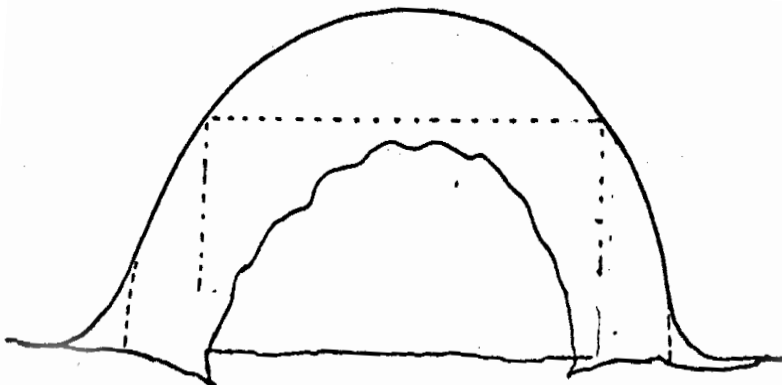

Ensure that all the writing on the film is readable from the inside (i.e. not mirror writing)

# Aligning the Sheet

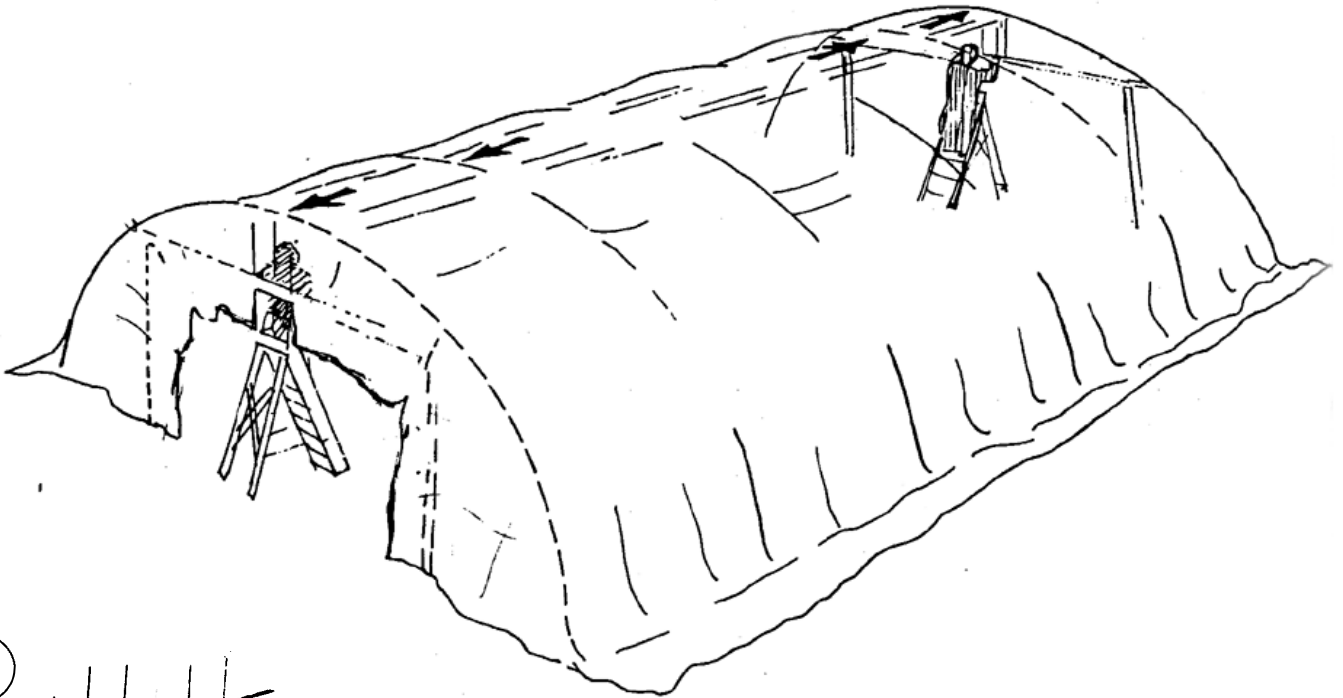

1) Stretch sheet tight from end to end along the length of the ridge.

2) Trim the sheet around door frame

3) Fix sheet to inside of cross timber ideally with a 2ft long, 2" x 1/2" (600mm long, 50mm x 12mm) timber batten, getting as much stretch as possible.

The method for this is :-

**A.** Roll a 2ft (600mm) Batten tightly in the polythene.

**B.** When maximum stretch has been obtained, place the edge of the batten on the inside edge of the door timber.

**C.** Lever the batten into place, thus getting more tension.

**D.** Fix the batten in place with 2" (50mm) nails.

4) Repeat the process at the other end, pulling sheet tightly along the ridge.

**NB:** Only fit the top batten of each end at this stage.

**A**

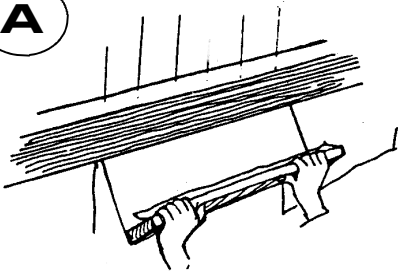

**B**

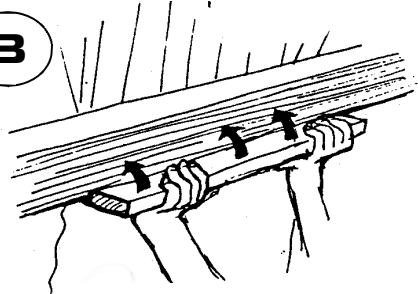

**C**

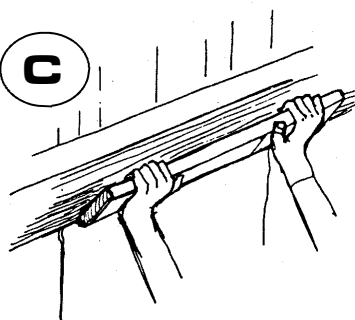

**D**

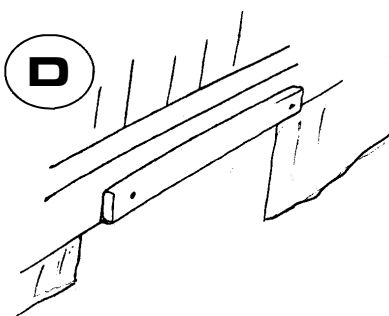

# Battening Around the Ends

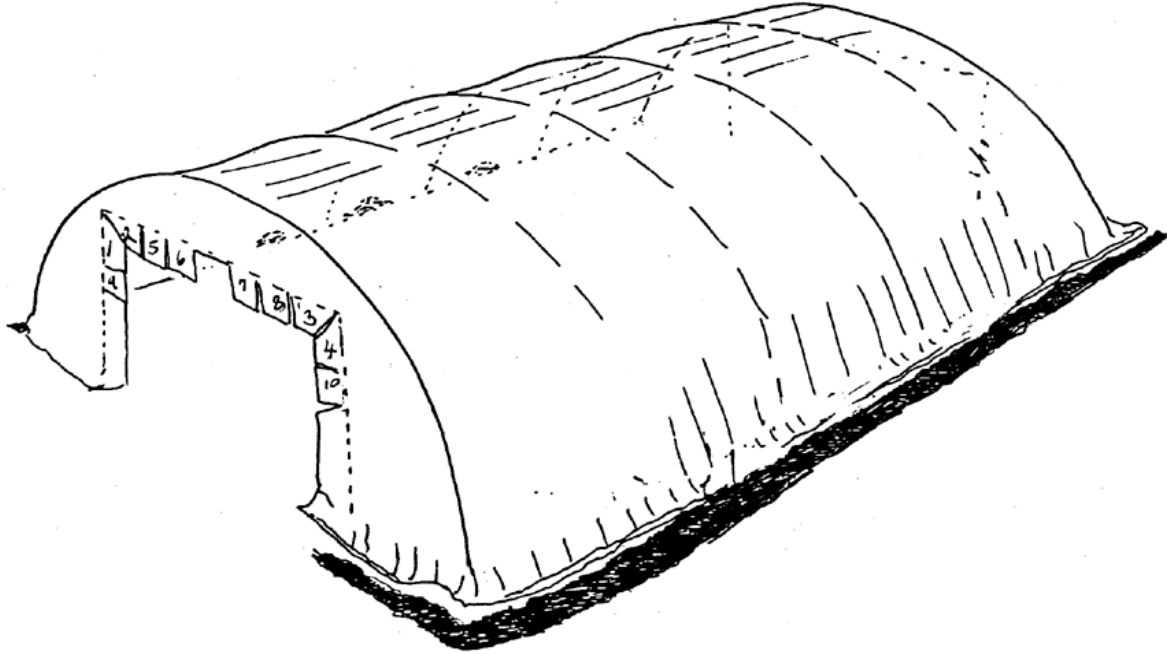

**1)** Tightly batten (as shown on previous page, A, B, C, and D ) around the top corners of the Door Frame.  
[in sequence 1, 2, 3, .....etc.].

**2)** Continue battening on the reverse side of the cross timber, incorporating folds or tucks where necessary.

# Initial Tensioning of Sheet

(When using the Trenching in Method)

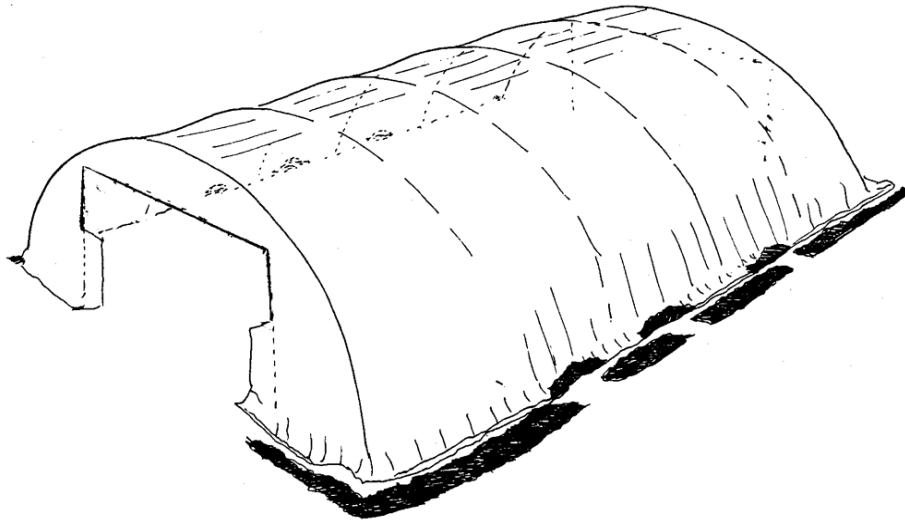

1) Place 3 or 4 shovels full of soil in the centre of each bay.

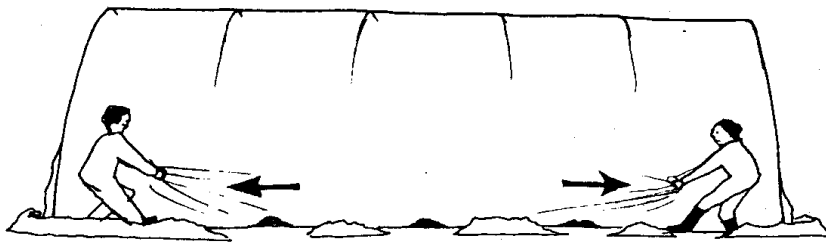

2) From the middle to each end pull sheet and soil along the bottom of trench from the centre to the end, removing any 'baggyness'.

3) From the middle to each end tension the sheet (see steps 4,5,6 and 7)

4) At each bay lift the sheet with the soil approx. 6" (150mm) from bottom of trench.

5) Still holding the sheet tread down heavily on the soil forcing it back into the trench, thus stretching the sheet

**NB: - This must be done on both sides simultaneously**

6) At this point more soil must be added and compacted before boot pressure can be removed

7) Between each pile of soil make a gash in the sheet at the bottom of the trench to allow for drainage.



8) Finally batten the remaining polythene at the 'goal post' ends as shown.

9) Refill the corner trenches

# Initial Tensioning of Sheet

(When using the Timber Base Rail Method)

## Important:

If your polythene was previously anchored using a trench and you have added your base rail as a modification, **DO MAKE SURE** that you have adequate concrete footings around each foundation tube to replace the weight of the soil lost. Also, Base rails should only be fixed to foundations and **NOT** to the hoops, as the hoops could lift off in a wind.

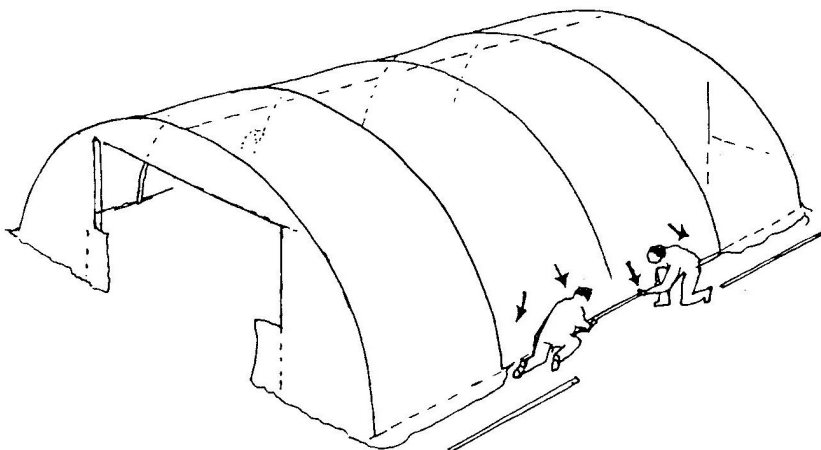

1) Clad house in normal way from the centre outwards and ensure the polythene sheet is aligned correctly on the structure, stretch the polythene lengthways as previously described.

**NB: - Ideally you will need approx. 300mm of polythene hanging over the base rail at each side.**

2) Starting from the centre on each side and working to either end, staple the edge of the sheet to one edge of a 3mtr x 50mm x 25mm Timber Batten. Roll the batten in the polythene approx. two full turns, slide it down the front face of the base rail timber and fix with 60mm nails approx 300mm apart. (Do not hammer the nails all the way in, in case you need to re-roll it)

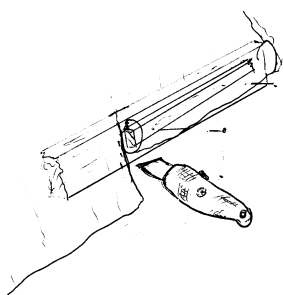
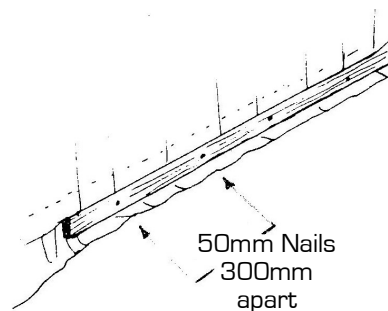

3) With a sharp knife carefully cut the rolled up polythene at one of the butt ends of the batten (hold the loose polythene securely to prevent a gust of wind ripping your cut further up the sheet). Roll another batten next to the first and so on until you are within 2.4m of the end hoop.

4) Batten the remaining polythene at the 'goal post' ends as previously described before coming back to finish off the last of the side sections.

**NB: The Object is to stretch the polythene as tight as possible with neat joints between the cladding battens.**

5) When you are satisfied, drive all the nails home.

# Final Tensioning of Sheet

To finally tension the sheet, lift each Hoop in turn approx. 50mm up on the Foundation Tubes and hold into place with a bracket or 'U' Bolt.

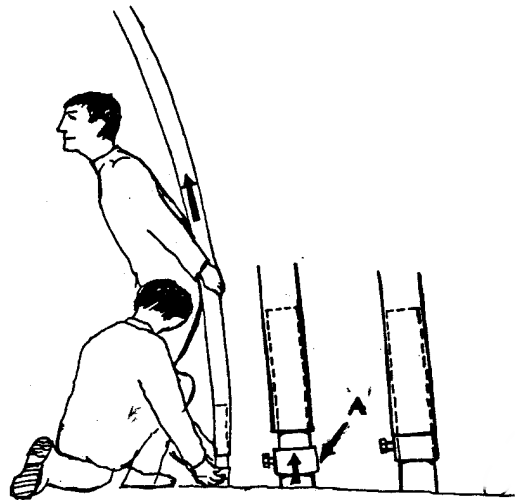

**Important:**

The importance of good sheet tensioning is vital to both the stability of the structure and the life of the sheet. As a general rule, when finished the polythene should be 'drum' tight, however, the polythene being quite flexible will expand and contract with varying temperatures.

# Cladding Doors and Louvre Vents

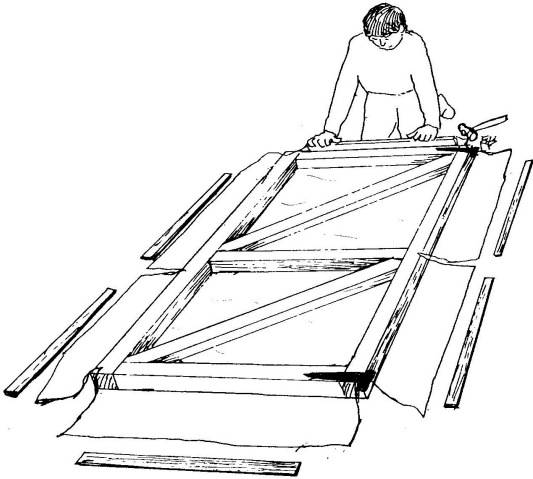

Cladding of doors/vents is best performed in a warm environment. This enables the polythene to stretch more easily.

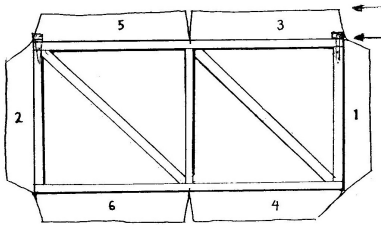

**1)** Lay the door/vent to be clad on a flat, clean patch of ground then lay the polythene over it and trim as shown - leaving 6" (150mm) around all edges.

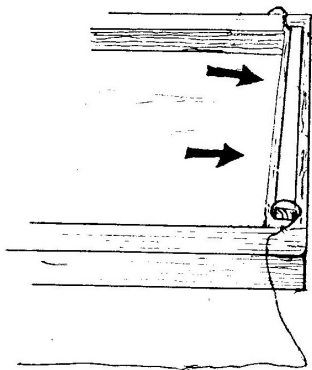

**2)** Roll thin battens (ideally 25mm x 12mm) timber battens tightly into the polythene and nail to the door/vent frame as shown. Roll and stretch the polythene in the battens as much as possible before nailing to obtain a neat, tight finish. Fix battens in sequence shown 1,2, etc.

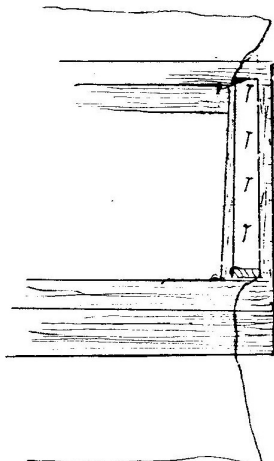

**3)** After securing the battens around all the sides of the frame, nail a batten to the cross rail to prevent the polythene from 'billowing'.